



10Gb 850nm Multi-Mode 300m SFP Transceiver BT-SFP-M03-11.1G

Features

- Up to 300m transmission on MMF
- Up to 10.3125Gbps
- 850nm VCSEL laser and PIN receiver
- SFI electrical interface
- 2-wire interface for integrated Digital Diagnostic monitoring
- SFP+ MSA package with duplex LC connector
- Hot pluggable
- Very low EMI and excellent ESD protection
- +3.3V power supply
- Power consumption less than 1.0W
- Operating case temperature: 0~+70°C

Applications

- High-speed storage area networks
- Computer cluster cross-connect
- Custom high-speed data pipes

Compliance

- Compliant with IEEE 802.3ae-2002
- Compliant with MSA SFF-8472
- Compliant with MSA SFF-8431

Description

BT-SFP-M03-11.1G is a high performance, cost effective modules, which is supporting up to 10.3125Gbps, and transmission distance up to 300m on MM fiber. The transceiver consists of two sections: The transmitter section incorporates a laser driver and a 850nm VCSEL laser. The receiver section consists of a PIN photodiode integrated with a transimpedance preamplifier (TIA) and a Limiting Amplifier. The module is hot pluggable into the 20-pin connector. The high-speed electrical interface is base on low voltage logic, with nominal 100Ohms differential impedance and AC coupled in the module.

The optical output can be disabled by LVTTTL logic high-level input of TX_DIS. Transmit Fault (Tx_Fault) is provided to indicate that the module transmitter has detected a fault condition related to laser operation or safety. Loss of signal (RX_LOS) output is provided to indicate the loss of an input optical signal of receiver. A serial EEPROM in the transceiver allows the user to access transceiver monitoring and configuration data via the 2-wire SFP Management Interface. This interface uses a single address, A0h, with a memory map divided into a lower and upper area. Basic digital diagnostic (DD) data is held in the lower area while specific data is held in a series of tables in the high memory area.



BORN
elegant creation

10Gb 850nm Multi-Mode 300m SFP Transceiver BT-SFP-M03-11.1G

Specification

Absolute Maximum Ratings					
Parameter	Symbol	Min.	Max.	Unit	Notes
Storage Temperature	T _s	-40	+85	°C	
Supply Voltage	V _{CC3}	0	3.6	V	
Relative Humidity	RH	5	+85	%	Note1
Rx Input Average Power	P _{max}	-	+1.5	dBm	

Notes:

[1] Non-condensing state.

Recommended Operating Conditions					
Parameter	Symbol	Min.	Typical	Max.	Unit
Operating Case Temperature	T _c	0	25	+70	°C
Power Supply Voltage	V _{CC3}	3.13	3.3	3.47	V
	I _{CC3}	-	-	300	mA
Power Dissipation	P _D	-	-	1.0	W
Data Rate			10.3125		Gbps

Transmitter Operating Characteristic-Optical, Electrical						
Parameter	Symbol	Min.	Typical	Max.	Unit	Note
Centre Wavelength	λ _c	800	850	900	nm	
Spectral Width	Δλ			1	nm	VCSEL
Laser Off Power	P _{off}	-	-	-30	dBm	
Average Optical Power	P _{avg}	-6	-	1	dBm	
Extinction Ratio	ER	3.5	-	-	dB	
Transmitter Dispersion Penalty	TDP	-	-	3.2	dB	
Relative Intensity Noise	RIN ₁₂ OMA	-	-	-128	dB/Hz	
Optical Return Loss Tolerance	ORLT	-	-	12	dB	
Operating Data Rate		-	10.3125	-	Gbps	
Optical Eye Mask	Compliant with IEEE 802.3ae-2002					
Tx Input Diff. Voltage	V _I	180	600	1000	mV	
Tx Fault	V _{oL}	-0.3	-	0.4	V	
	V _{oH}	2.4	-	V _{cc} +0.3		



10Gb 850nm Multi-Mode 300m SFP Transceiver BT-SFP-M03-11.1G

Receiver Operating Characteristic-Optical, Electrical

Parameter	Symbol	Min.	Typ.	Max.	Unit	Note
Center Wavelength	λ_r	800		900	nm	
Receive Sensitivity In Average Power	Psen	-	-	-11	dBm	
Los Assert	LosA	-25	-		dBm	
Los Dessert	LosD	-	-	-16	dBm	
Los Hysteresis	LosH	0.5	-	6	dB	
Overload	Pin	-	-	-1	dBm	
Receiver Reflectance		-	-	-12	dB	
Operating Data Rate	-	-	10.3125	-	Gbps	
Rx Output Diff Voltage	Vo	300	600	1200	mV	

Notes:

[1] Receiver sensitivity is informative. Stressed receiver sensitivity shall be measured with conformance test signal for BER = 1×10^{-12} .

Digital Diagnostic Functions

Parameter	Symbol	Min.	Max.	Unit	Note
Temperature monitor absolute error	DMI_Temp	-3	3	°C	Over operating temp
Laser power monitor absolute error	DMI_TX	-3	3	dB	
RX power monitor absolute error	DMI_RX	-3	3	dB	
Supply voltage monitor absolute error	DMI_VCC	-3%	+3%	V	
Bias current monitor absolute error	DMI_Ibias	-10%	10%	mA	

Control and Status I/O Timing Characteristics

Parameter	Symbol	Min.	Max.	Unit	Note
TX Disable Assert Time	t_off	-	100	μ s	Note1
TX Disable Negate Time	t_on	-	2	ms	Note2
Time to initialize including reset of TX_Fault	t_init	-	300	ms	Note3
TX Fault Assert Time	t_fault_on	-	1	ms	Note4
TX Fault Reset Time	t_reset	10	-	μ s	Note5
LOS Assert Time	t_loss_on	-	100	μ s	Note6
LOS Deassert Time	t_loss_off	-	100	μ s	Note7

Notes:

- [1] Time from rising edge of TX Disable to when the optical output falls below 10% of nominal
- [2] Time from falling edge of TX Disable to when the modulated optical output rises above 90% of nominal
- [3] From power on or negation of TX Fault using TX Disable
- [4] Time from fault to TX fault on
- [5] Time from TX fault to TX nominal



BORN
elegant creation

10Gb 850nm Multi-Mode 300m SFP Transceiver BT-SFP-M03-11.1G

- [6] Time from LOS state to RX LOS assert
- [7] Time from non-LOS state to RX LOS deassert.

Pin-out Definition

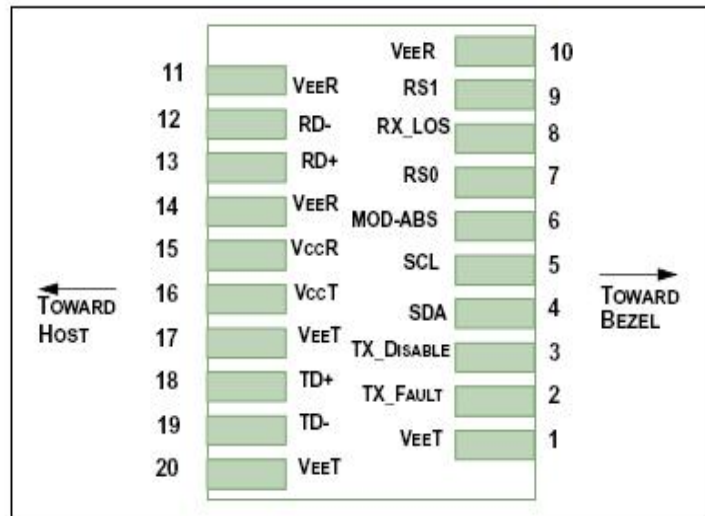

Figure1

Pin Assignment

Pin	Logic	Symbol	Name/Description	Note
1		VeeT	Module Transmitter Ground	
2	LVTTL-O	TX_Fault	Module Transmitter Fault	
3	LVTTL-I	TX_Disable	Transmitter Disable; Turns off transmitter laser output	
4	LVTTL-I/O	SDA	2-wire Serial Interface Data Line (Same as MOD-DEF2 as defined in the INF-8074i)	
5	LVTTL-I/O	SCL	2-wire Serial Interface Clock (Same as MOD-DEF1 as defined in the INF-8074i)	
6		MOD_ABS	Module Absent, connected to VeeT or VeeR in the module	
7	LVTTL-I	RS0	Not used	
8	LVTTL-O	RX_LOS	Receiver Loss of Signal Indication (In FC designated as RX_LOS, in SONET designated as LOS, and in Ethernet designated at Signal Detect)	
9	LVTTL-I	RS1	Not used	
10		VeeR	Module Receiver Ground	
11		VeeR	Module Receiver Ground	
12	CML-O	RD-	Receiver Inverted Data Output	
13	CML-O	RD+	Receiver Non-Inverted Data Output	
14		VeeR	Module Receiver Ground	
15		VccR	Module Receiver 3.3 V Supply	

16		VccT	Module Transmitter 3.3 V Supply	
17		VeeT	Module Transmitter Ground	
18	CML-I	TD+	Transmitter Non-Inverted Data Input	
19	CML-I	TD-	Transmitter Inverted Data Input	
20		VeeT	Module Transmitter Ground	

Block Diagram of Transceiver

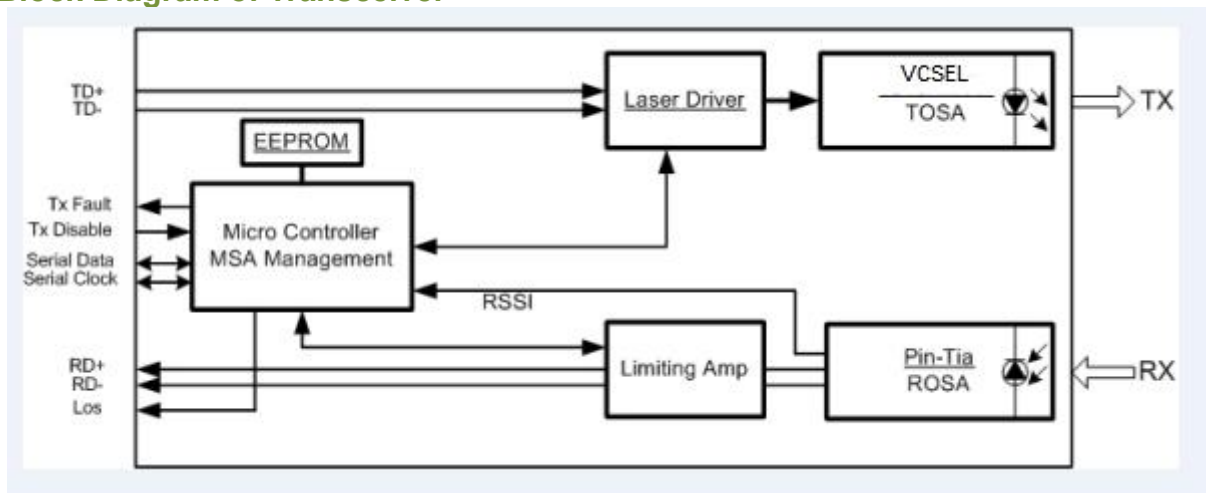

Figure2

Transmitter Section

The transmitter converts 10Gbit/s serial PECL or CML electrical data into serial optical data compliant with the 10GBASE-SR standard. An open collector compatible Transmit Disable (Tx_Dis) is provided. A logic "1," or no connection on this pin will disable the laser from transmitting. A logic "0" on this pin provides normal operation. The transmitter has an internal automatic power control loop (APC) to ensure constant optical power output across supply voltage and temperature variations. An open collector compatible Transmit Fault (Tx_Fault) is provided. TX_Fault is a module output contact that when high, indicates that the module transmitter has detected a fault condition related to laser operation or safety. The TX_Fault output contact is an open drain/collector and shall be pulled up to the Vcc_Host in the host with a resistor in the range 4.7-10 kΩ. TX_Disable is a module input contact. When TX_Disable is asserted high or left open, the SFP+ module transmitter output shall be turned off. This contact shall be pulled up to VccT with a 4.7 kΩ to 10 kΩ resistor

Receiver Section

The receiver converts 10Gbit/s serial optical data into serial PECL/CML electrical data. An open collector compatible Loss of Signal is provided. Rx_LOS when high indicates an optical signal level below that specified in the relevant standard. The Rx_LOS contact is an open drain/collector output and shall be pulled up to Vcc_Host in the host with a resistor in the range 4.7-10 kΩ, or with an active termination. Power supply filtering is

recommended for both the transmitter and receiver. The Rx_LOS signal is intended as a preliminary indication to the system in which the SFP+ is installed that the received signal strength is below the specified range. Such an indication typically points to non-installed cables, broken cables, or a disabled, failing or a powered off transmitter at the far end of the cable.

Recommended Interface Circuit

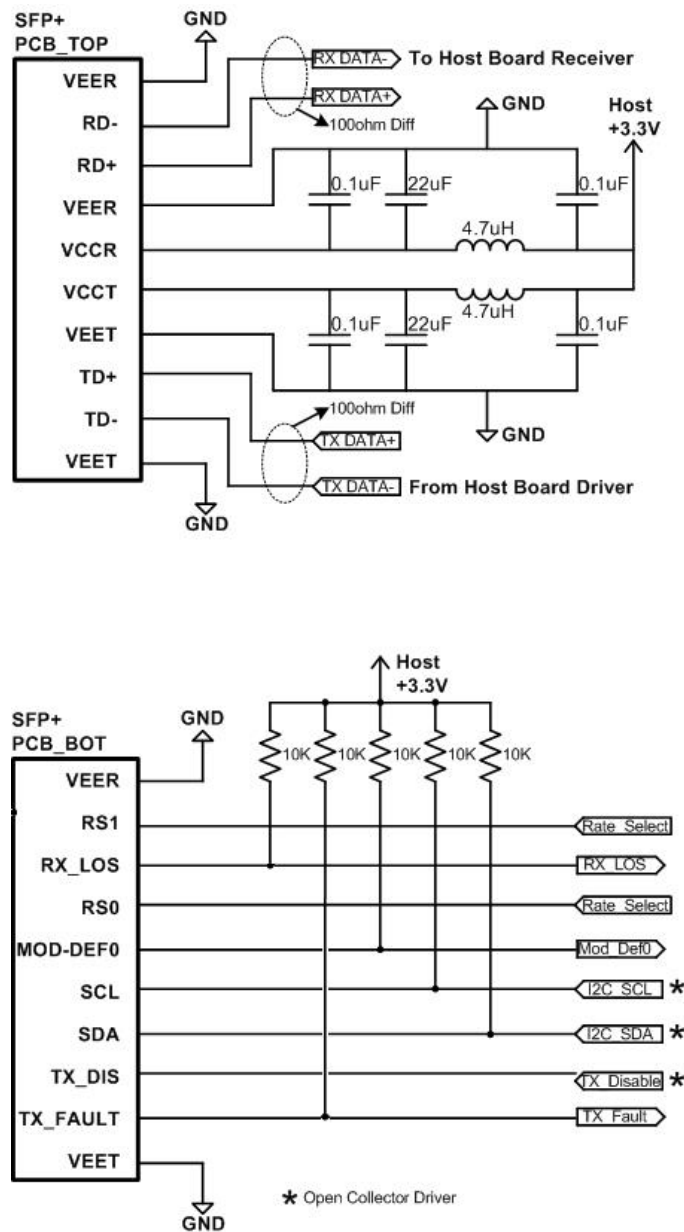

Figure3



BORN
elegant creation

10Gb 850nm Multi-Mode 300m SFP Transceiver BT-SFP-M03-11.1G

Digital Diagnostic Memory Map

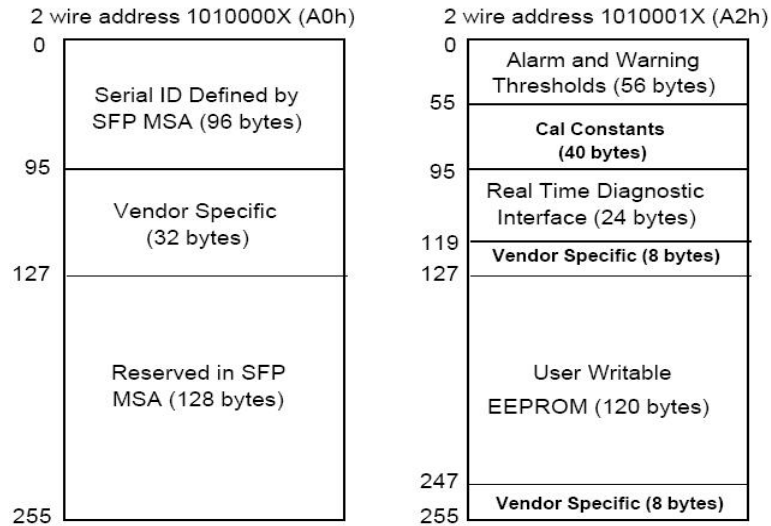

Figure4

Mechanical Specifications

